

Model HD 300

MAGNETIC STRENGTH

Plate Magnets are available as standard in high strength 890 or latest Rare Earth/Neodymium range of materials. All these materials are truly permanent magnets and will give many years of maintenance free use. Rare/Earth/Neodymium models are the same size but have the letter 'N' after the model type i.e. HDN.

DESCRIPTION

Plate Magnets are supplied standard with hinge and latch plates. The Magnetic face and all contact parts are stainless steel. The raised poles are designed to give maximum holding power and reduce wear of face. See reverse side page PM-2 for standard stock sizes. Larger or special sizes can be made to suit requirements.

APPLICATION

Plate Magnets are installed in inclined feed chutes to remove metal contamination for the protection of process machinery i.e. Mills, Grinders, Rolls, Conveyors, Elevators and also for purifying Product before packaging. They can also be supplied in our standard housing, see leaflet PH.1-2.

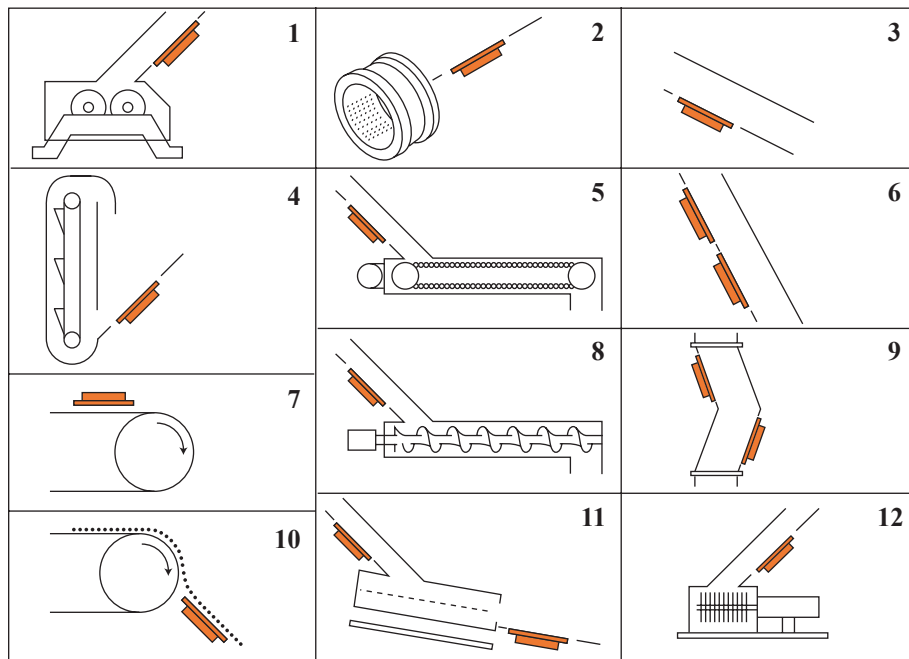

INSTALLATION POINTS

1. Rolls
2. Pallet Mills
3. Feed Chutes
4. Elevators
5. Chain Conveyors
6. Two in-line
7. Over Conveyors
8. Screw Conveyor
9. Vertical Duct
10. Conveyor Discharge
11. Feeder & Screen
12. Rotary Mills

INSTALLATION

Plate Magnets are quick and easy to install. They should be fitted at the top of duct where product speed is slowest. If product speed is excessive or incline of duct is too steep a further magnet can be added in-line.

MAGNETIC SEPARATIONS LTD

14 MEADOWSIDE ROAD. CHEAM, SURREY SM2 7PF

TEL: 020 8642 4413/4 FAX: 020 8642 9476

E-MAIL: info@magneticseparations.com WEBSITE: www.magneticseparations.com

TYPE: PM PLATE MAGNETS

THREE MODELS: LD, MD AND HD

Leaflet PM-2
2003

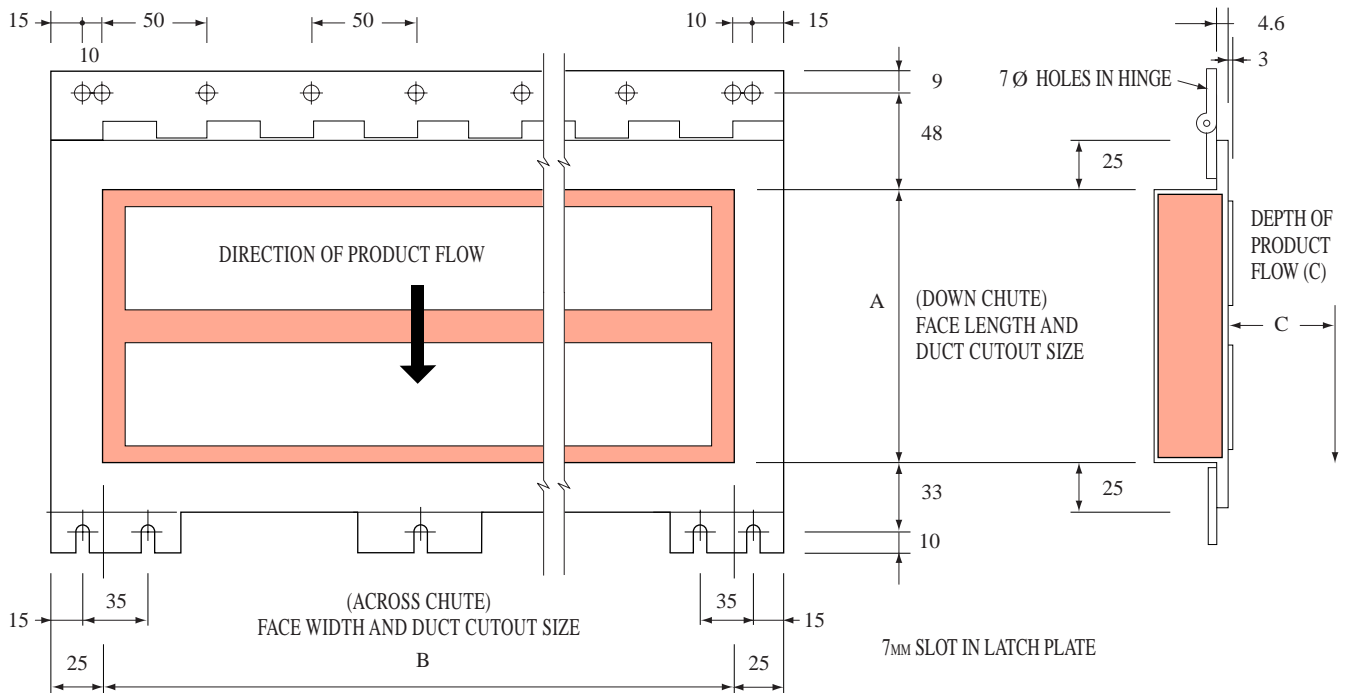

TO ORDER : STATE MODEL AND FACE WIDTH (i.e. HD 150)

3 Models	A	B (FACE WIDTH)												C	WEIGHT EACH 100MM OF (B)
		100	150	200	250	300	350	400	450	500	550	600			
LD (Light Duty)	130	100	150	200	250	300	350	400	450	500	550	600	65	3Kg	
MD (Medium Duty)	200	100	150	200	250	300	350	400	450	500	550	600	100	7Kg	
HD (Heavy Duty)	265	100	150	200	250	300	350	400	450	500	550	600	130	10Kg	
Latch Plate No. Off		2	2	2	2	2	3	3	3	3	4	4			

INSTALLATION NOTES

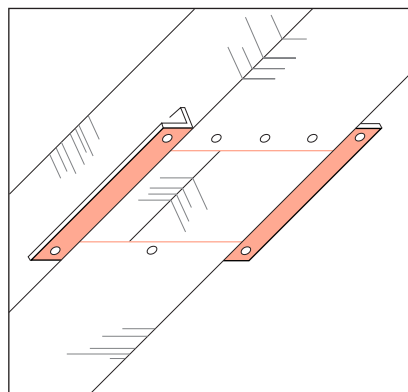

Cut out Chute base to face length(A) and width (B). Fit side angle flanges.

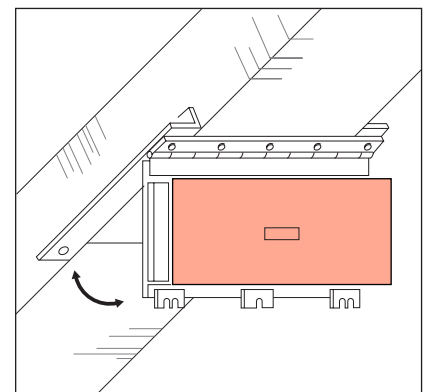

Fit Hinge to top of cutout and space hinge to suit thickness of gasket (if used).

MAGNETIC SEPARATIONS LTD

14 MEADOWSIDE ROAD. CHEAM, SURREY SM2 7PF

TEL: 020 8642 4413/4 FAX: 020 8642 9476

E-MAIL: info@magneticseparations.com WEBSITE: www.magneticseparations.com